



# Product Catalog

## 2021/2022



## Truck Accessories

The last toolbox you will ever buy.

[www.BCIFabrication.com](http://www.BCIFabrication.com)

## Contents

---

About BCI Fabrication-----	2
Mission Statement-----	2
Truck Accessories	
Standard Fuel/Toolbox Combinations-----	3-6
Uncommon Fuel/Toolbox Combinations-----	7-9
L-Tank Combinations-----	10-11
Stand-alone Fuel Tanks-----	12
Stand-alone Toolboxes-----	13-14
Sideboxes-----	15-16
Underbody Boxes-----	17
Running Boards-----	18-19
Warranty-----	20
Dealerships-----	21
Contact-----	Back Cover

## About BCI Fabrication

---

BCI Fabrication, LLC is a manufacturer of quality toolboxes, fuel tanks, and accessories for both commercial and personal pickup trucks. Based in the panhandle of Oklahoma, we craft all of our products in Beaver, Oklahoma with materials produced within the US. We pride ourselves in leading the industry with commitment, leadership, and innovation. Our toolboxes and fuel tanks are known nationwide, and we believe in serving our dealers and end users with honesty and integrity by offering longevity and trust with every single product we manufacture. At BCI Fabrication, we set our priority in ensuring we will provide you with the last toolbox you will ever buy.

## Mission Statement

---

*At BCI Fabrication, LLC, we have made it our mission to build quality and precision into every single product we craft. From using only American-made materials to ensuring our products exceed each and every customer's expectations, we have established our company by setting the standard higher than the rest.*

## Standard Fuel tank/Toolbox Combinations

All of our standard toolbox and fuel tank combinations feature a diesel tank with a toolbox welded directly to it. Welding the toolbox and fuel tank together produces a more structurally sound tank. This combined with the fact that we use thick, 12-gage steel allows us to provide every tank with an unprecedented 3-year warranty. Each of our Standard Series products feature a handy oil cage and they are coated with the rugged Line-X coating.

These combinations are considered our “Standards” because they all feature our rugged 10” and 13” toolboxes. These toolboxes are 60” long and 18” wide. The “10” or “13” designates the height or depth of the toolbox. All of our standard tanks can be fitted with either 10”, 13”, or 18” toolboxes, and each toolbox can be built with either 1 or 2 lids. For more information, please visit our website: [BCIFabrication.com](http://BCIFabrication.com).

### FTB50-10

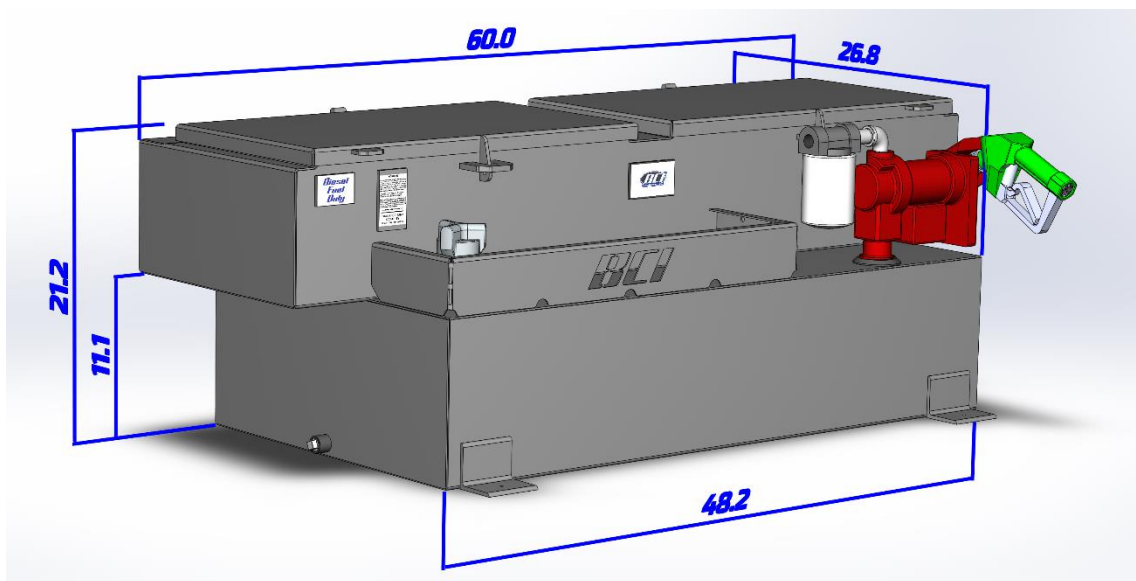

The box that started it all. This was the first product ever made at BCI Fabrication and continues to be one of our best sellers. This product is a 50-gallon tank with a 10” tall toolbox welded solidly to it. This is probably the best option for short-bed pickups that want a decent fuel capacity and a large toolbox. It is designed so that the tank fits between the fender wells and the box sits above them. Most pickup beds are about 24” deep and 63” wide, so this combo provides great functionality without taking away from the look of the truck. Moreover, if they can’t see it, they are less likely to try to break into it.

## FTB70-10

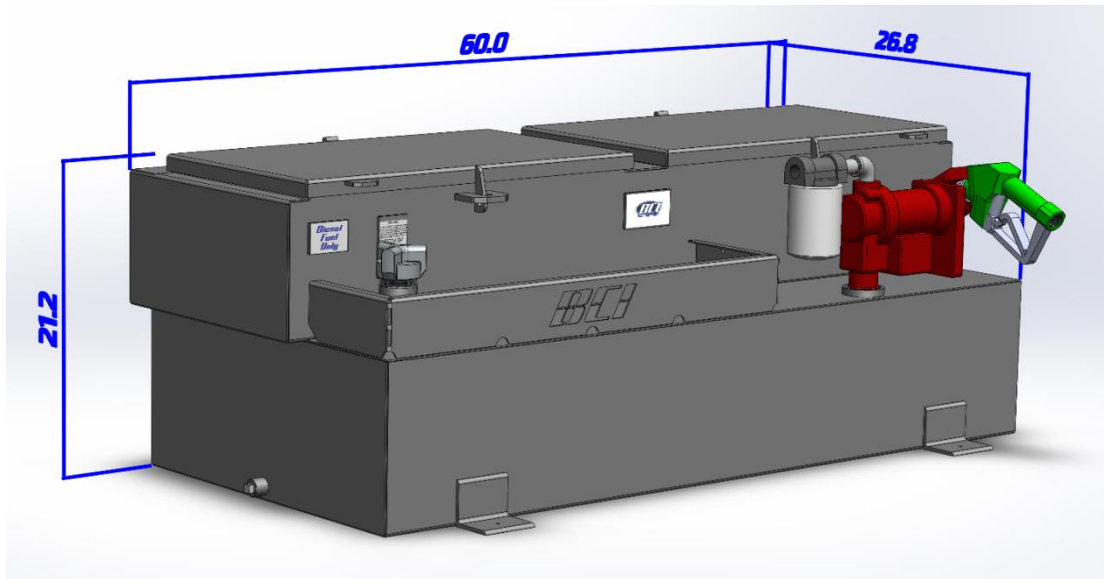

The 70-10 is just like the 50-10 except it has a 70 gallon capacity. This combo works great for long-bed pickups that have a fifth wheel. Make sure to measure your bed to find the best product to fit your needs. Contact us if you need more information on any of our products.

## FTB70-10M

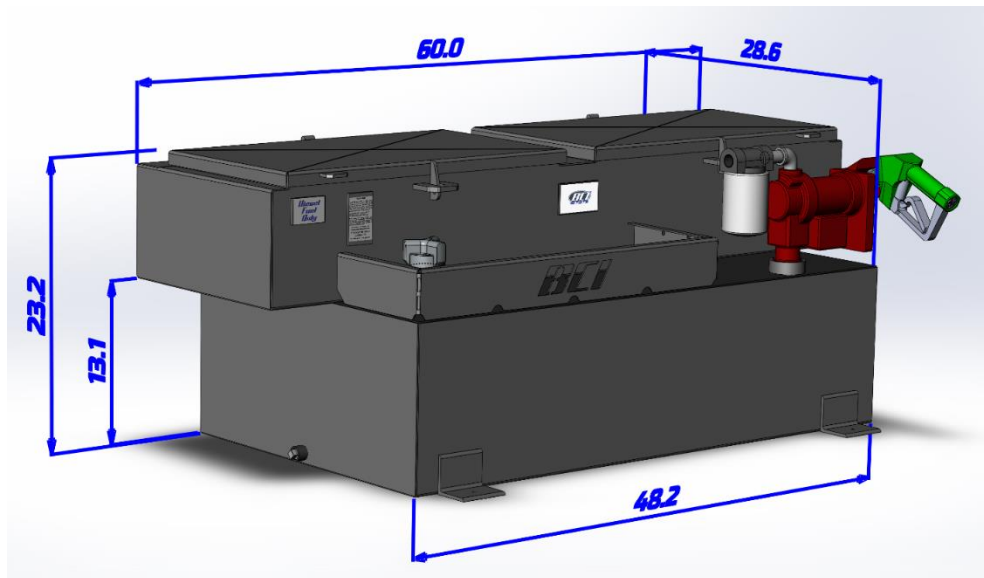

The 70-10M – or the “seventy-ten modified” as we call it in the shop – is built just like the 50-10, but the tank is 2” taller and 2” wider. This allows the owner to shove an amazing 70 gallons in without taking up much more room. This product should still fit any short-bed pickup.

## FTB90-10

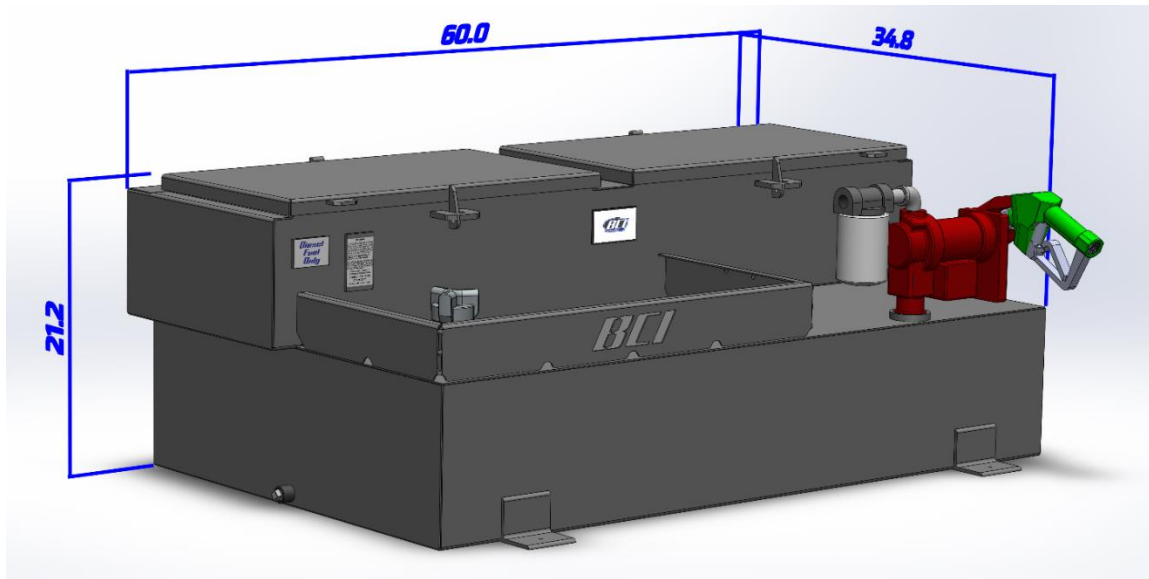

The 90-10 is another classic BCI box. This tank is one of our best sellers for long-bed pickups. It features a large 90-gallon tank with all of the great features of our Standard Series products.

## FTB100-10

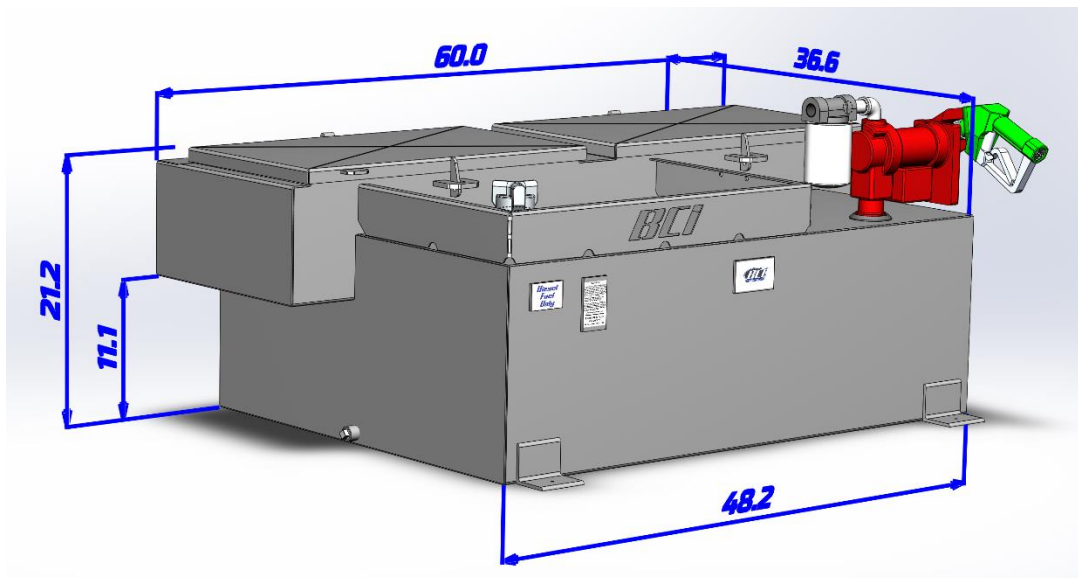

When you want it all, this is the toolbox for you. This tank is massive, with a 100-gallon capacity and a 10" toolbox, it has just about everything you need, but it can fit in a short-bed! That's right; this monster is designed to fit between the fender wells of your pickup. Remember, any of our Standard Series combos can be outfitted with the larger 13" and 18" toolboxes. However, with the 10" toolbox, it still sits below the bedrail of most pickups to remain inconspicuous.

## FTB100-10R

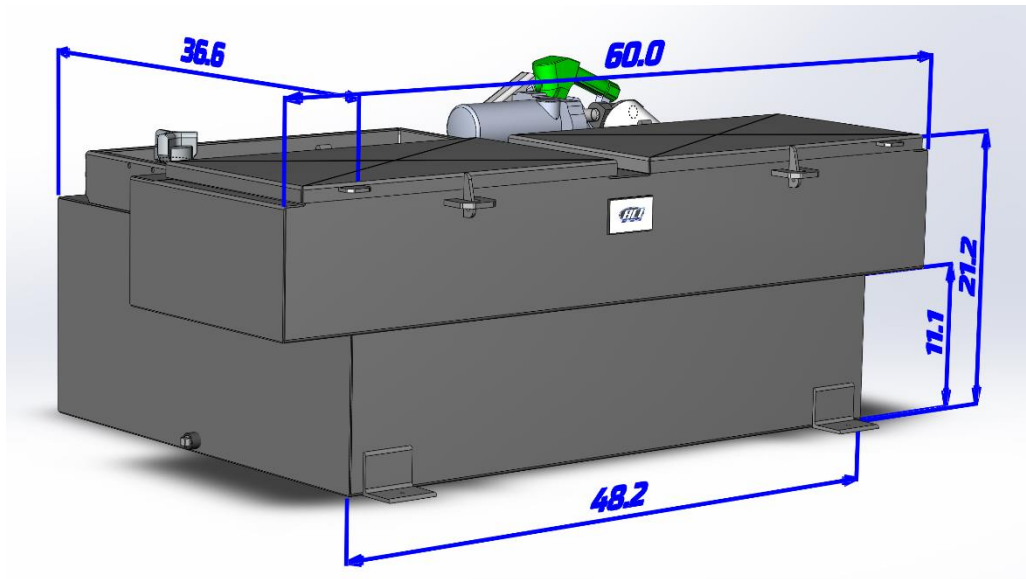

Like the FTB100-10, this 100-10 “reversed” combo provides a 100-gallon capacity with our standard 10” toolbox. The only difference is that we have flipped the toolbox to the other side. This makes it a little easier to get to the toolbox and it tucks the fill-neck and pump away toward the cab.

## Uncommon Toolbox/Fuel Tank Combinations

We refer to these as the uncommon combinations because they don't fit any other category. They are unique to the other products we build. However, they are all still built with 12-gage steel and coated with Line-X polyurea coating.

### FTB50-8

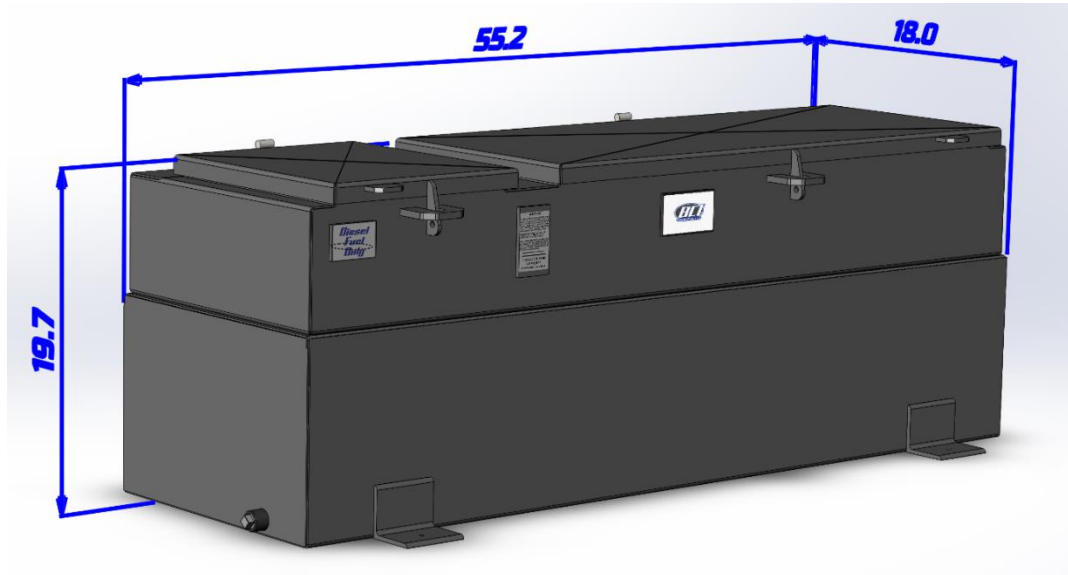

The 50-8 features an eight inch toolbox atop a 50-gallon tank. This product is unique because it does not feature a pump outlet and the fill neck is locked within the toolbox. There are two compartments in the toolbox: a large one on the passenger side to store tools and the one on the driver side which houses the fill neck.

### DM50

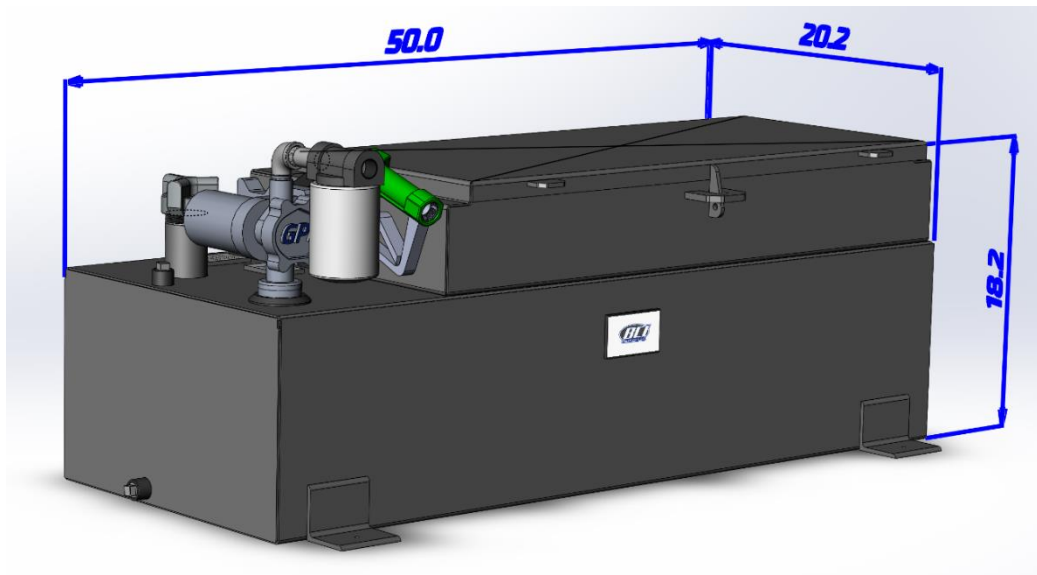

A great option where space is limited. This features a surprisingly roomy toolbox (even though it is only 6" tall) atop a 50-gallon tank.



## M3 or Mayfield

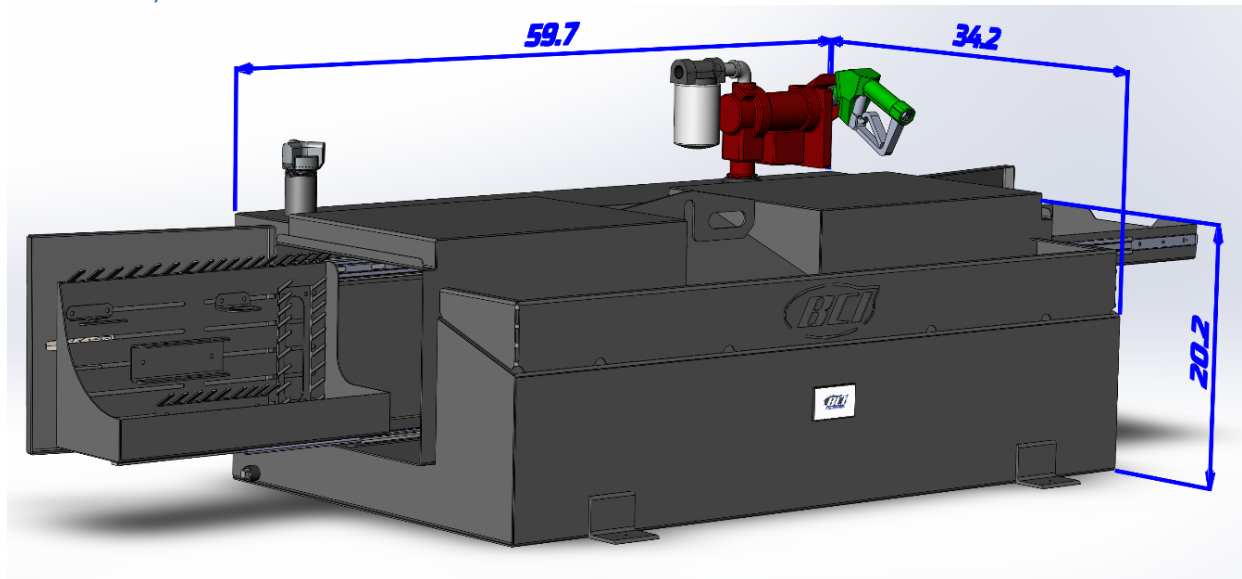

We call it the Mayfield because it was Mr. Mayfield that ordered it first. We have spent a lot of time developing this product and it has turned into one of our favorites. You won't find another like it. This features a 90-gallon tank with two sideboxes and a oil cage. The driver side toolbox includes a tool organizer tray, and the passenger side houses a drawer. The two boxes are connected through the tank so that long tools can be stored inside and seal shut with locking twist latches. A great option for surveying equipment or other long tools.

## FBC35

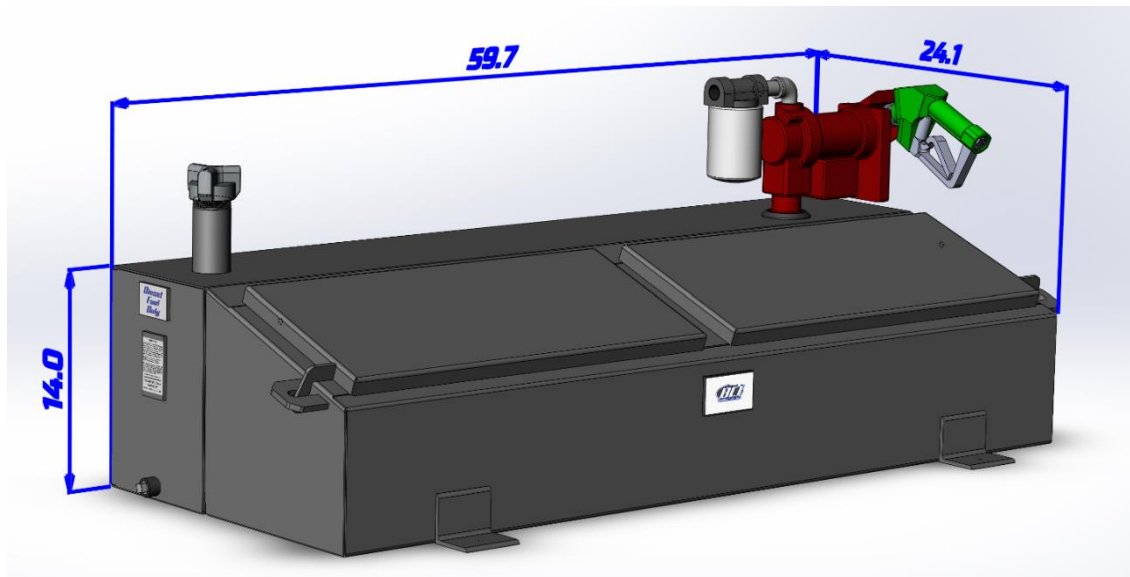

The FBC35 is just an all-around good box. It looks great and fits in just about anything. It has a quaint 35-gallon tank and a large, slanted toolbox.

FBC50

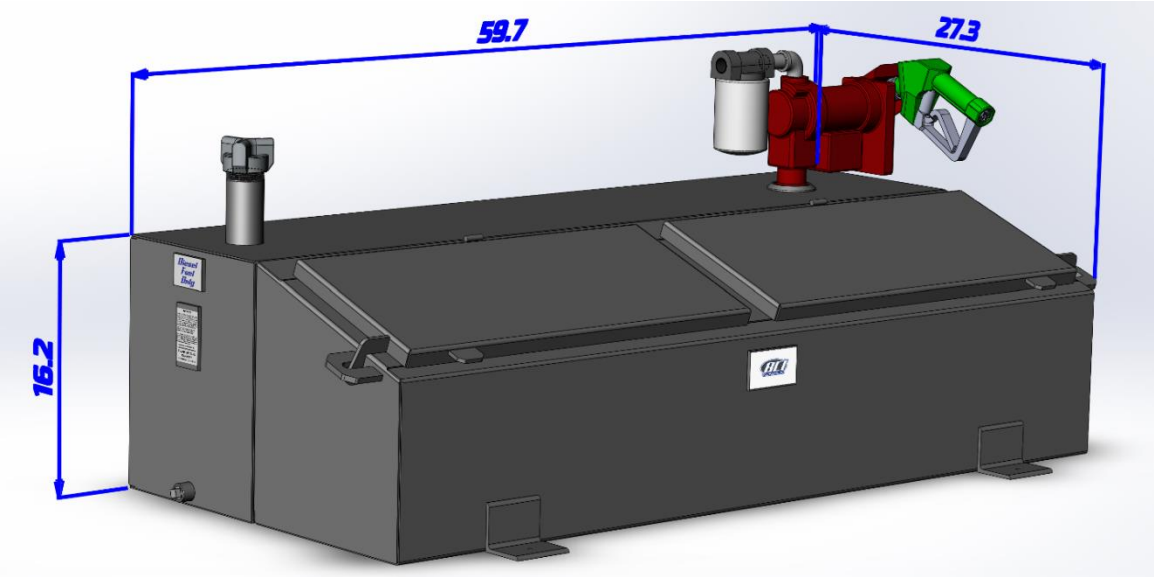

The FBC50 is just like the FB35 except it's bigger. It features a 50-gallon tank and a large slanted toolbox.

## L-Tank Combinations

Our L-tank combos are built just as rugged and with the same textured coating as our Standard Series Combos, but in a compact design. Like our Standard Series Combos, these toolboxes are also welded directly to the tank. This strengthens the tank and prevents rubbing between the tank and box, which could shorten the life of the tank. These products also feature a lift hook, which makes them a great option for platforms.

### LTB80

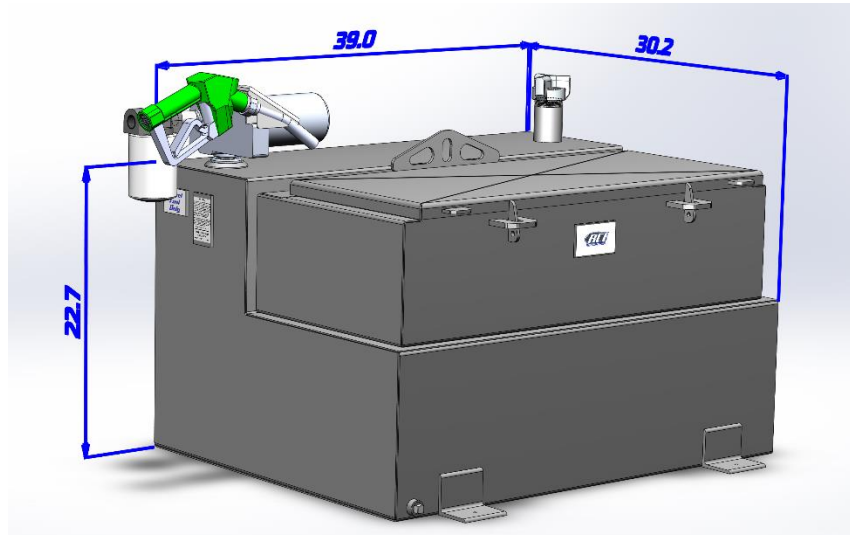

This combo was designed specifically to fit between the side boxes on a utility bed. However, it works great for many other applications. It features an adequate 80-gallon tank and a sizeable toolbox.

### LTB95

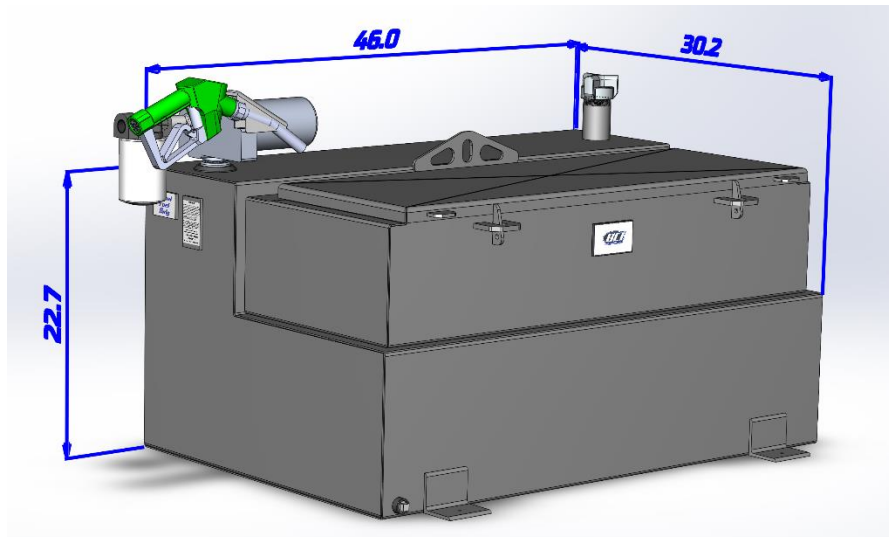

Like the LTB80, the LTB95 was designed to fit between the sideboxes on the TM beds by CM Truck Beds. Many of our customers use these boxes in a wide variety of applications though. Their cube-like shape and lift hook makes them a great option for crane and platform use. The LTB95 is just a little bigger to provide a whopping 95-gallon capacity.

L100-18

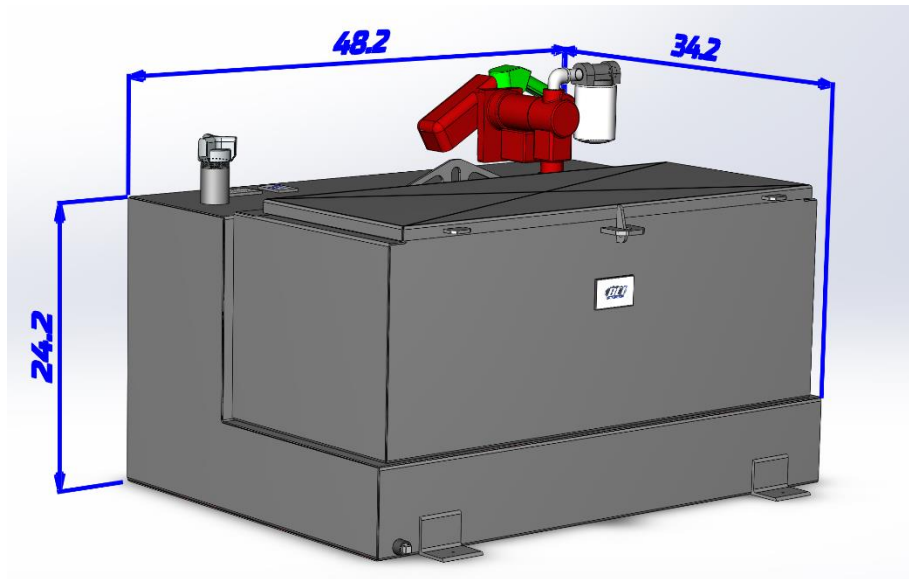

The L100-18 puts 100 gallons and huge toolbox in the most compact package possible. This toolbox is deep; 18 inches deep and 20 inches wide. You cannot get more capacity in such a small package.

## Stand-alone Fuel Tanks

Just like our combinations, our stand-alone auxiliary fuel tanks are built with heavy-duty 12-gage steel and they are coated with the Line-X polyurea coating. More sizes available!

### FT50

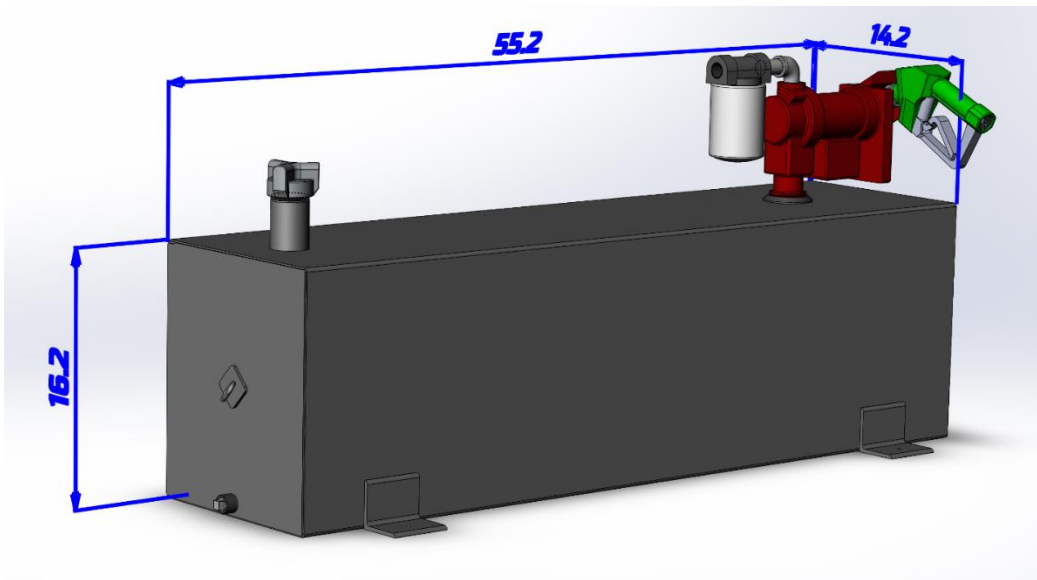

The FT50 is what the name suggests; a 50-gallon fuel tank with rugged 12-gage construction.

### FT100

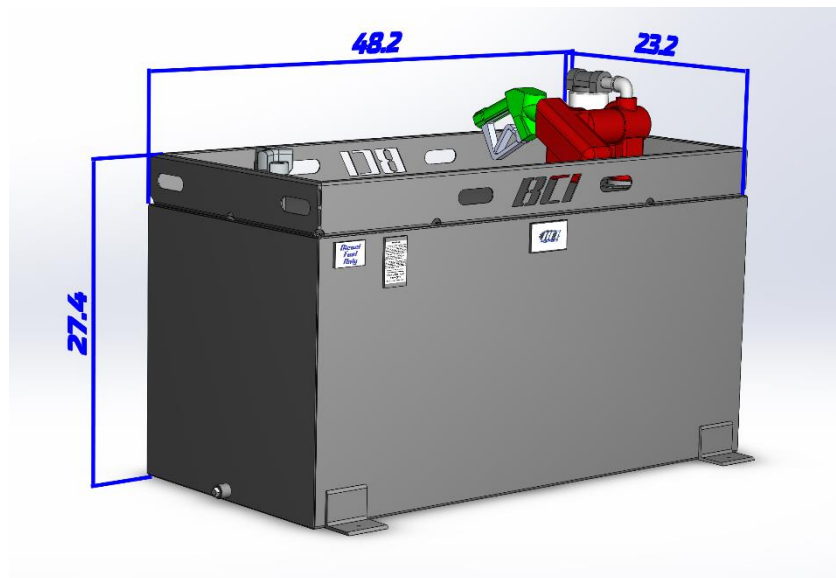

You've seen these rectangular, 100-gallon tanks everywhere, but none built as heavy. Our FT100 features heavy-duty baffles and 12-gage steel to make an extremely durable tank. This product also features a handy oil cage on top to provide a little extra storage. Warrantied against leaks for 3-years after the date of purchase.

## Stand-alone Toolboxes

All of our toolboxes feature cross-broke lids, Line-X polyurea coating, removable tool trays, and 12-gage steel construction. The cross-break on the lids helps to strengthen the lid and to shed water and mud. There are more sizes available.

### TB10

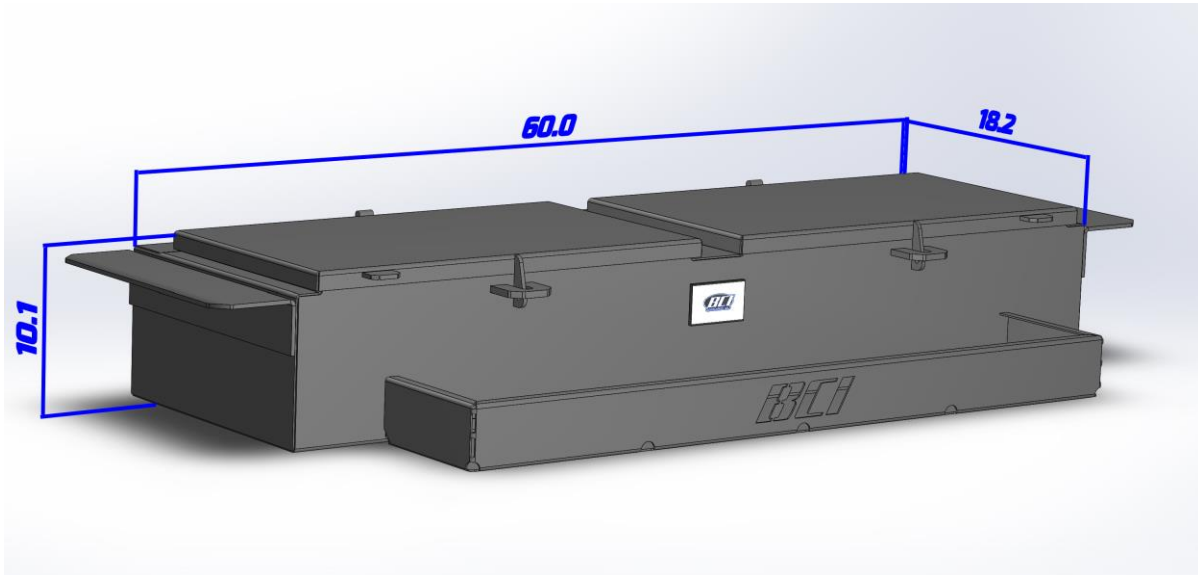

This is the same toolbox found on our Standard Series Combinations, but rigged to sit on the side-rails of your pickup. We can build this toolbox with either one or two lids, with or without the side-rail mounting arms, and with or without the oil cage.

### TB13

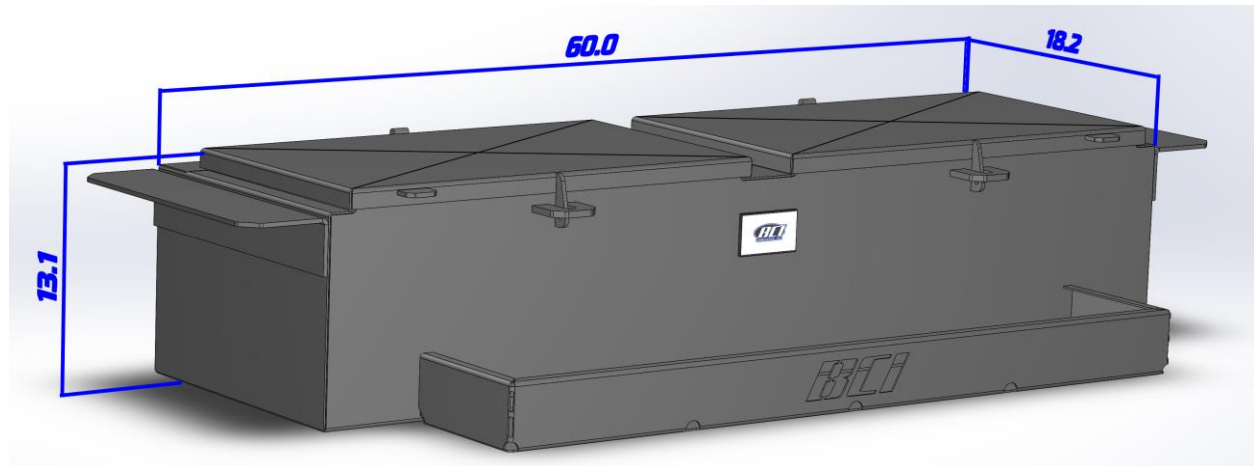

Just like the TB10 this box can be built with or without the side-rail mounts, with one or two lids, and with or without the oil cage.

TB18

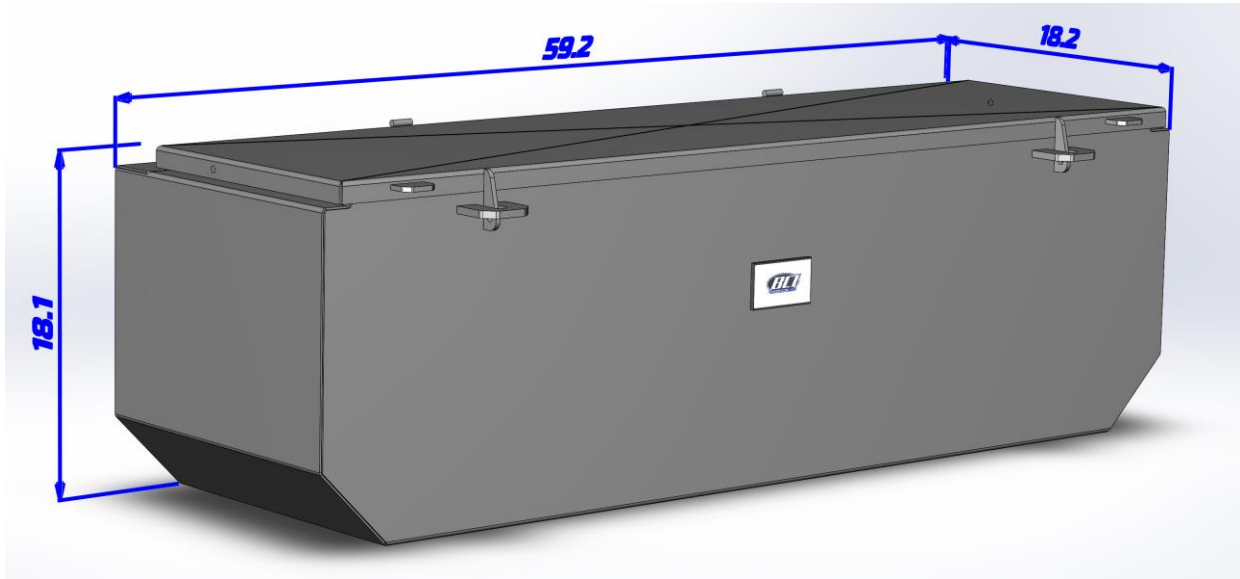

Shown without the oil cage or side-rail mounting arms and with a single lid. This is our largest toolbox and it can hold most anything you might need. Most people who buy this toolbox store large equipment inside of it and they need a large opening, but we can make this toolbox with two lids as well.

TB18-48

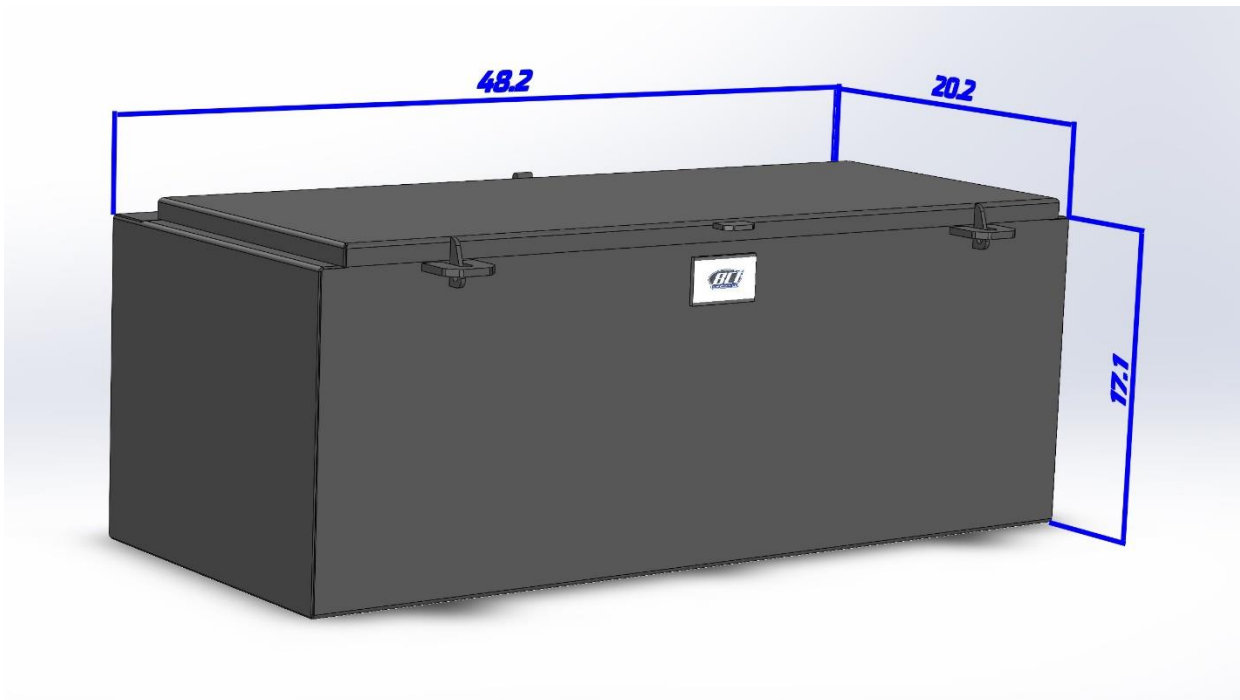

The TB18-48 is a great option for when you need a lot of storage in a small space. This toolbox is narrow enough to fit between the fender wells in the beds of most trucks, but it isn't so tall that it's visible above the bedrail.

## Sideboxes

Sideboxes make a great addition to any truck. They provide a lot more storage without taking much room. Our Sideboxes are coated with Line-X polyurea coating to match all of our other products. These boxes also include a small tray to help organize your tools and hardware.

SB3

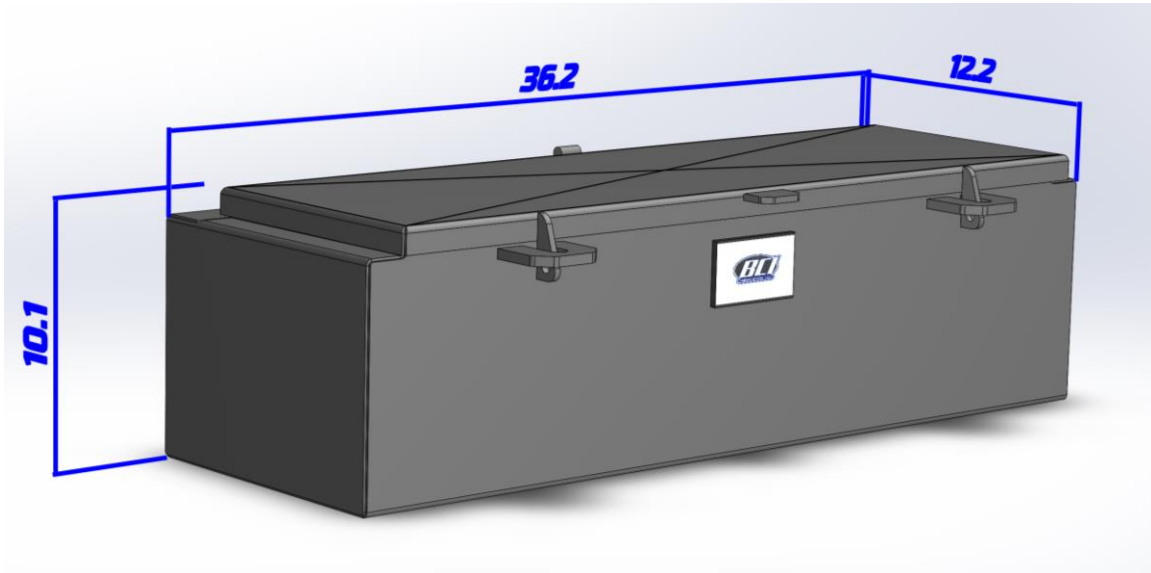

A 3-foot sidebox doesn't seem like much, but these are an excellent storage option. Not only do these work great for sideboxes, but they also make a great general storage solution. These are only available with one lid. Can be configured for flatbed or fleet-bed trucks. Refer to the SB5 for an example of the fleet-bed setup.

SB4

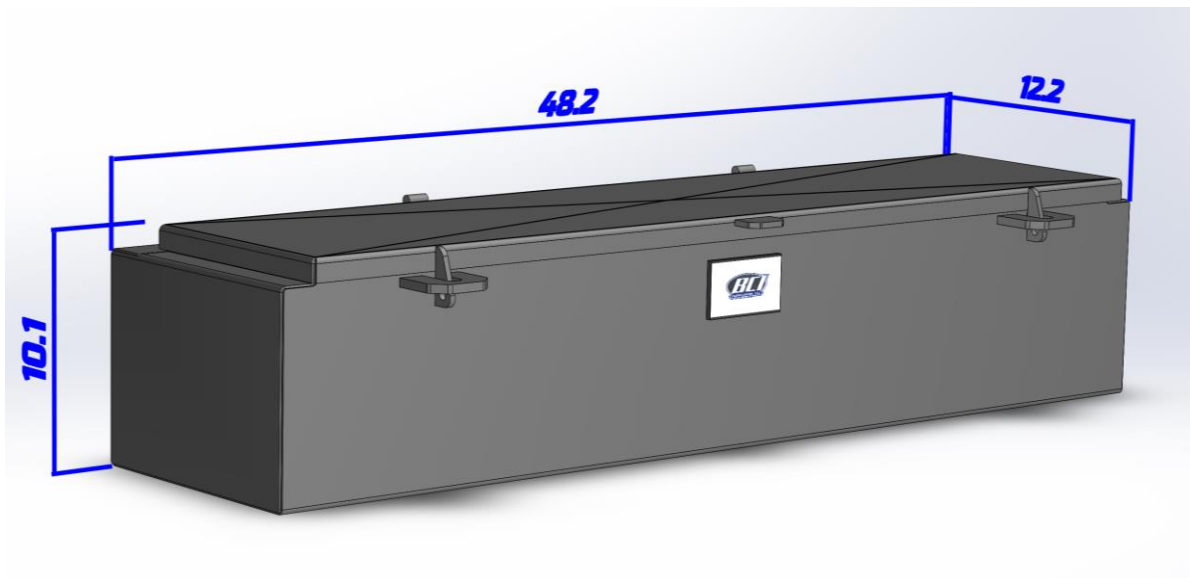

The 4 foot sidebox is also only available with one lid. Shown here in a flatbed configuration, but also available in a fleet-bed configuration. Refer to the SB5 on the next page for an illustration of a fleet-bed setup.



SB5

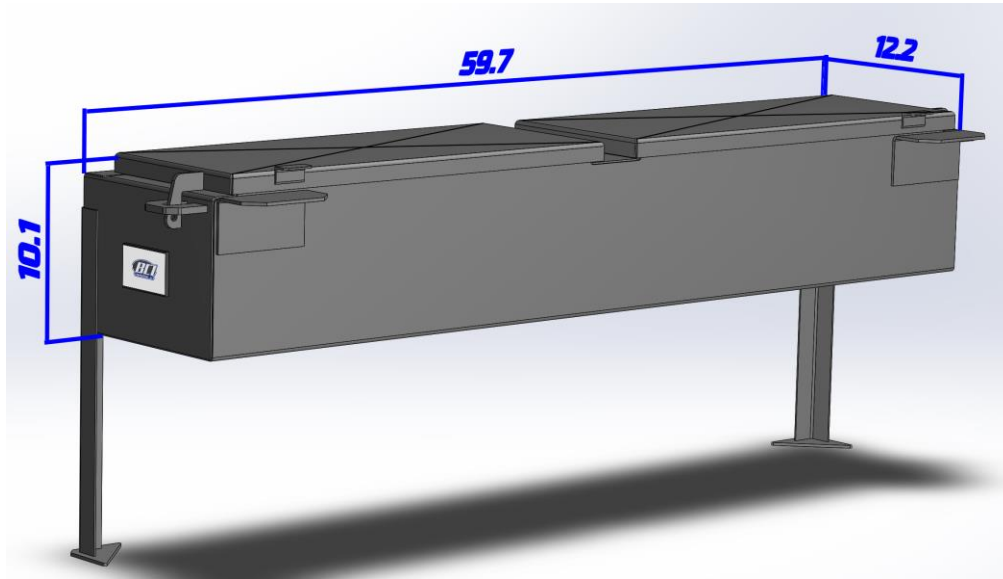

Shown with 2-lid option and fleet-bed configuration. This box is available with one or two lids and flatbed or fleet-bed setup. There are two tabs near the top of the box that rest on the side-rail of your fleet-bed pickup. Two legs reach to the floor of your bed to provide a rigid setup that won't damage your side rails.

SSB5

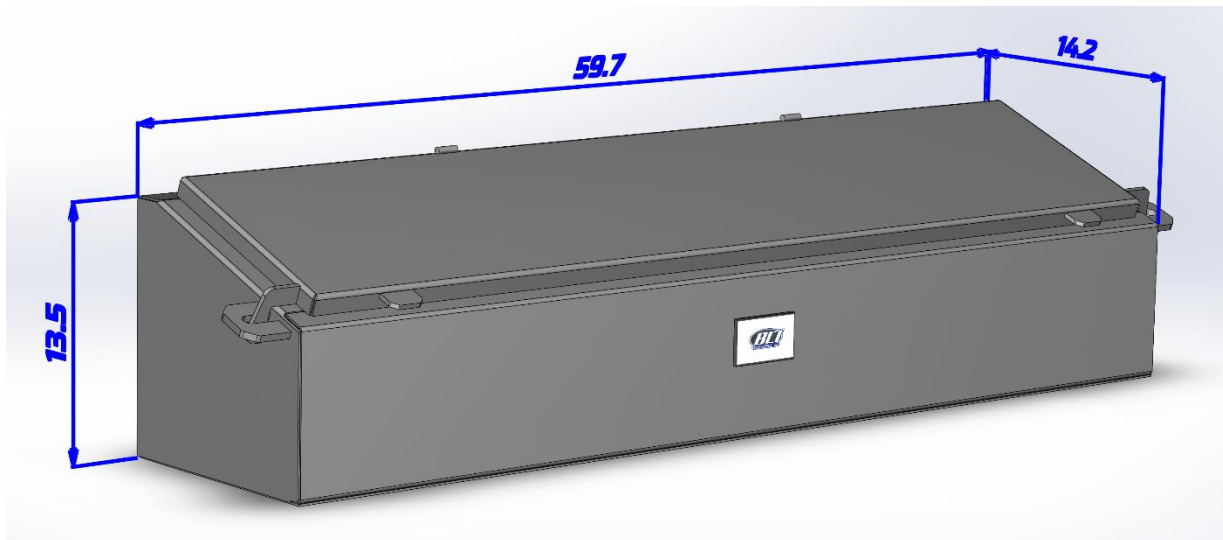

These slant side boxes provided a sleek option for flatbeds. The slant makes it easy to see down inside of these. One or two lid options are available, but they do not include a tray.

## Underbody Boxes

Another great option for extra storage. These boxes mount under a flatbed, but can be mounted anywhere storage is needed. These are also coated with the Line-X Polyurea coating and they feature a locking twist-latch and 12-gage steel construction to keep your tools safe. Below are just a couple examples. More sizes are available.

UBX24-24

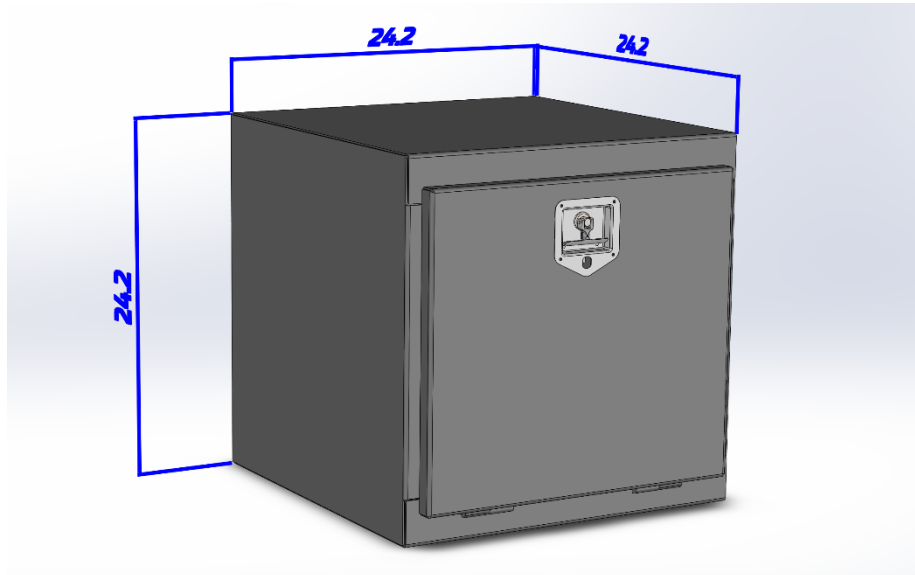

This product can be mounted below your bed, on top of another toolbox, or anywhere extra storage can be used. The doors on these boxes are supported with chains so that you can use the door to rest heavy objects on.

UBX36-18

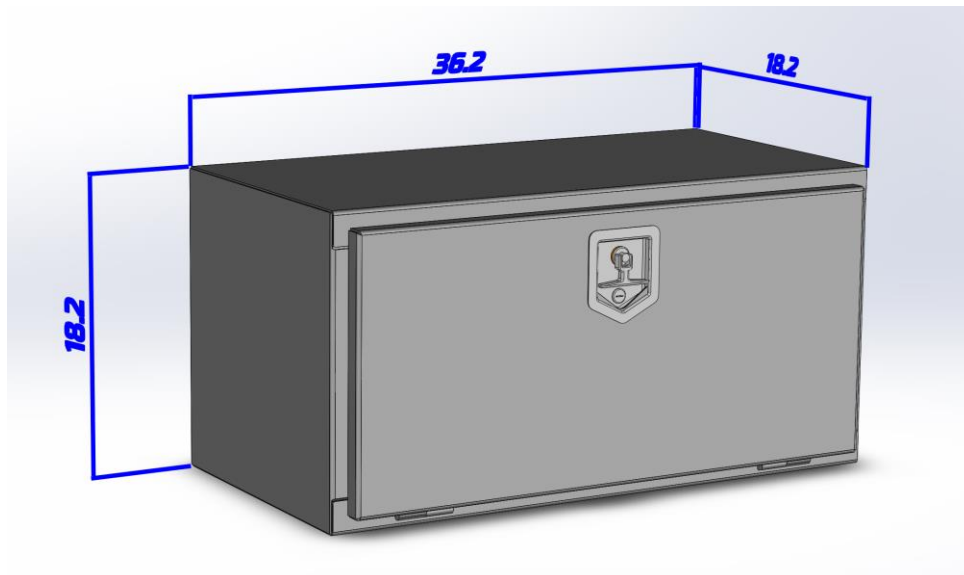

Here is another size option. Again, there are more sizes available.

## Running Boards

We also fabricate running boards for 2012-2020 Chevrolet, 2017-2020 Dodge, & 2015-2020 Ford. Our boards are 5.2" wide and tubular. We offer lengths of 48" for single cabs, 78" for extended cabs, 86" for crew cabs, & 120" for select models. These boards are coated with a Line-X polyurea coating to provide a textured surface for improved grip. Our standard design is the BCI board shown below. For a small fee we will make your boards custom. Put your logo, name, or custom design in your running boards.

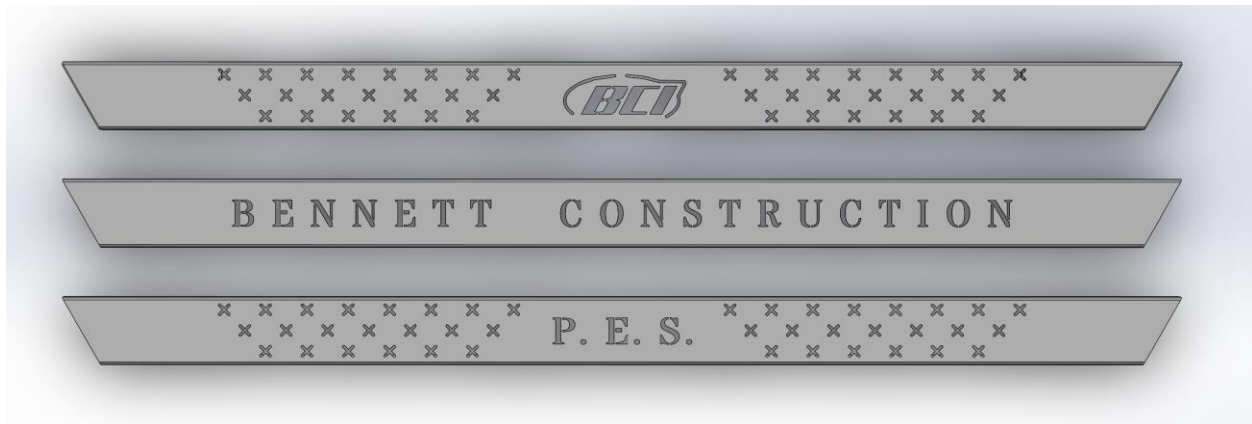

Standard BCI board design on a 2019 crew-cab Dodge.



Custom board design for a 2020 single-cab Ford



Standard BCI board design on a 2019 crew-cab Dodge.



Custom board on 2020 single-cab Ford.

## Warranty

---

Provided that the Customer registers his or her product using the online registration form provided at [www.BCIFabrication.com/guarantee](http://www.BCIFabrication.com/guarantee), BCI Fabrication, LLC warrants that said product(s) will be free from defects in material or workmanship upon delivery and for three (3) years immediately thereafter (the "Warranty"). As Customer's sole remedy for breach of the Warranty, BCI Fabrication will replace the goods with replacement goods of equal or comparable value, or repair the goods, at BCI Fabrication's sole option within 2 weeks of request of replacement.\*

If you are unsure where your product's serial number is located, please call (580) 625-5091.

## Our Dealers

### **2-D Trailer Sales**

535 S 4<sup>th</sup> St  
Clinton, OK 73601  
(580) 323-3999

### **A Oilfield Supply**

US-283  
Laverne, OK 73848  
(580) 921-3376

### **BENCO Machinery**

7600 N Bryant Ave  
Oklahoma City, OK 73121  
(866) 554-8277

### **BES Supply Store**

1909 N 1<sup>st</sup> St.  
Artesia, NM 88210  
(575) 887-3550

### **BS Trailer Sales**

1900 E Wyatt Earp Blvd  
Dodge City, KS 67801  
(888) 277-2537

### **C Bar H Farm Supply**

3502 Campus Drive  
Garden City, KS 67846  
(620) 275-2153

### **Double Barrel Fabrication**

4202 Christoval Road  
San Angelo, TX 76904  
(325) 500-8970

### **Double J Truck Beds**

14 Ave E  
Beaver, OK 73932  
(580) 527-0234

### **FabCon**

1850 CR 269  
Leander, TX 78641  
(512) 259-1269

### **Farm Source**

1300 West Hwy 77  
Perry, OK 73077  
(580) 307-4666

### **Frontier Accessories, Inc.**

717 S. Main St.  
Perryton, TX 79070  
(806) 202-3881

### **Glenn Polk Ford**

4320 N I-35  
Gainesville, TX 76240  
(940) 668-8770

### **Kempner Equipment**

2403 E Hwy 190  
Lampasas, TX 76550  
(512) 564-1866

### **Lonestar Truck & Trailer Sales**

1303 N. Main St.  
Seminole, TX 79360  
(432) 758-3280

### **McKinsey Motors Ford**

1415 US-183  
Clinton, OK 73601  
(580) 323-0259

### **Midwest Trailers & Service**

406 US-54  
Hooker, OK 73945  
(580) 522-1757

### **Prestige Auto Accessories**

101 S Hobart St  
Pampa, TX 79065  
(806) 665-3500

### **Platinum Auto Services**

606 S. Canal St.  
Carlsbad, NM 88220  
(575) 689-6900

### **R&D Truck Accessories**

1734 N Jefferson  
La Grange, TX 78945  
979-206-2244

### **Roach Body Shop & Wrecker Service**

3800 Oklahoma Ave  
Woodward, OK 73801  
(580) 256-7234

### **Stephenville Trailers**

810 East Road  
Stephenville, TX 76401  
888-565-5670

### **Stillwater Milling Company**

502 E 6<sup>th</sup> Ave.  
Stillwater, OK 74075  
(405) 372-2766

### **Tireworks Inc.**

420 W. 1<sup>st</sup> St.  
Hereford, TX 79045  
(806) 364-5033

### **TNT Hydraulic, Inc.**

720 W. Pine  
Liberal, KS 67901  
(620) 624-6829

### **Tops & Stripes Vehicle Accessories**

3535 W Owen K. Garriott Rd  
Enid, OK 73703  
(580) 234-4095

### **Truckfitters**

1039 N Loop 12  
Irving, TX 75061  
(972) 914-2225

### **West Texas Off-Road Center**

915 W 42nd  
Odessa, TX 79764  
(432) 366-0081

### **Whiteface Customs**

3997 US HWY 60  
Hereford, TX 79045  
(806) 360-4432

### **W.O.G. Supply**

625 E. Hondo Ave  
Devine, TX 78016  
(830) 663-6100

### **ZK Express, Inc.**

3228 N Grimes St  
Hobbs, NM 88240  
(575) 492-9613

## Contact Us

---

### **BCI Fabrication, LLC**

¾ Mile West on CR14  
Beaver, OK 73932

#### **Brian Starr**

**Facility Manager**

**580-527-1744**

#### **Shaun Noyes**

**Sales Manager**

**580-522-1090**

#### **Jake Templin**

**Design/Sales**

**620-655-8963**

For all other matters, our main office may be

reached at:

**580-625-5091**

